

With Internal Limitation Of The Rotation, vibration Resistant Quarter Turn Lock  
2930

Heavy duty swinghandle Lock  
3202

Index

Locks

RL P65 NEW

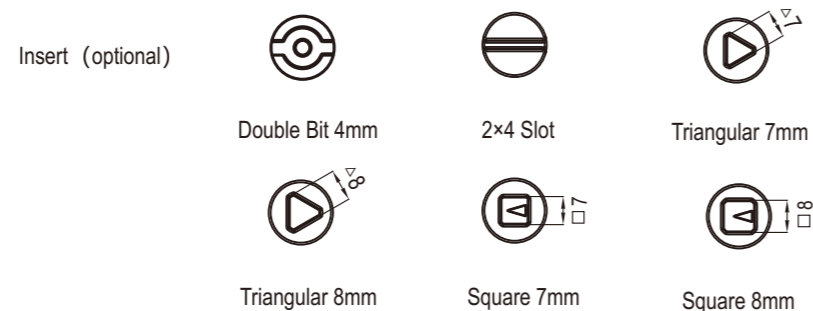
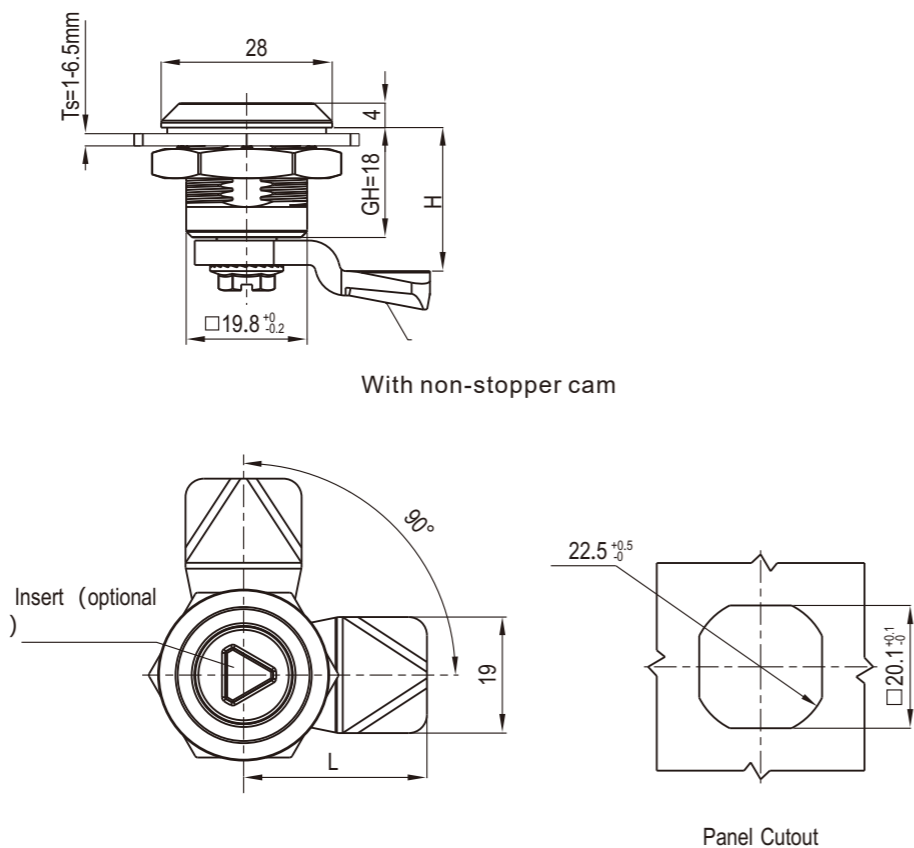
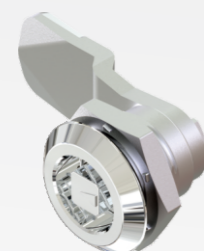
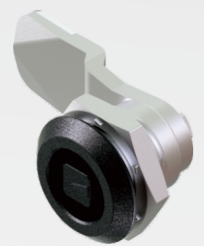
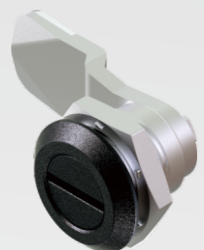
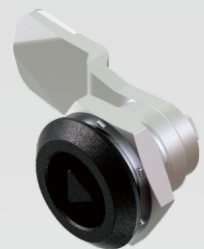

Zinc die handle and housing; black textured powder coated or bright chrome; m.s. zinc plated cam

Insert type	Bright Chrome	Black Textured Powder Coated
Double Bit 4mm	2930-028-60	2930-028-40
2-4 Slot	2930-048-60	2930-048-40
Triangular 7mm	2930-074-60	2930-074-40
Triangular 8mm	2930-076-60	2930-076-40
Square 7mm	2930-094-60	2930-094-40
Square 8mm	2930-096-60	2930-096-40

Accessories ref. to page #  
1. CAM ref. to page 9A-001  
2. With non-stopper cam

RL P65

Index

Locks

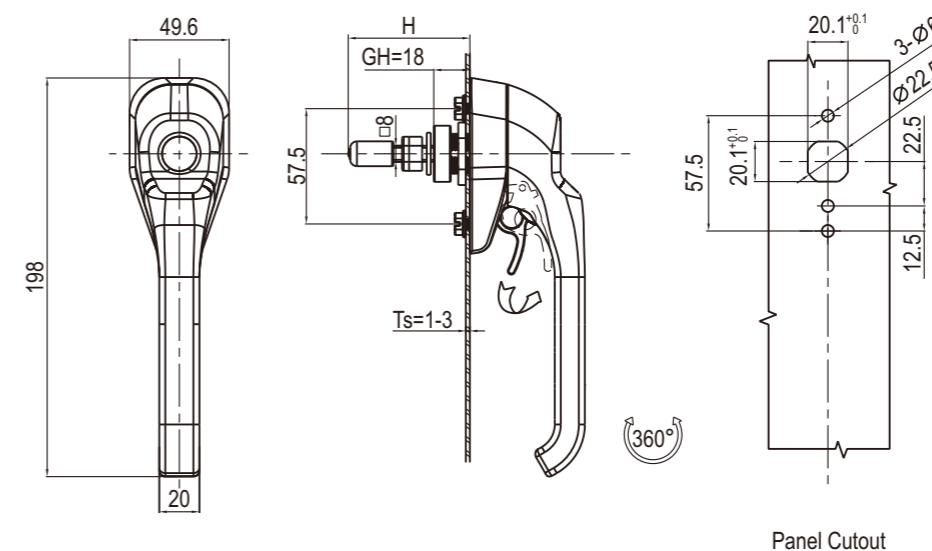
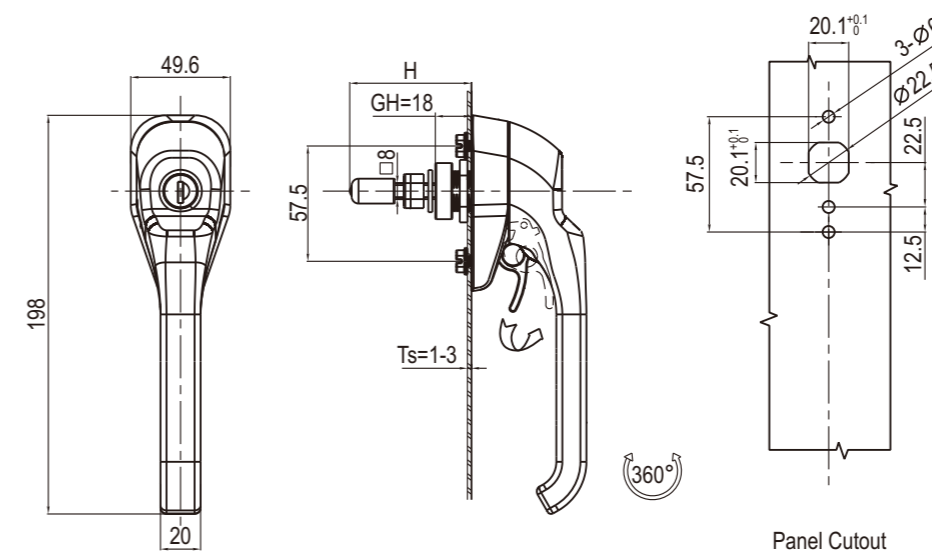

Zinc die, black textured powder coated

	Black Textured Powder Coated	SUS 316
YK333 key locking	3202-220-40	3202-220-632
Non-locking	3202-100-40	3202-200-632
2X4 slot	3202-048-40	

Accessories ref. to page #  
1.CAM ref. to page 9A-001

Remark

- Key different on request
- CH751 key code on request
- Padlockable on request
- Keyed YK333