

Slam-lock

3600

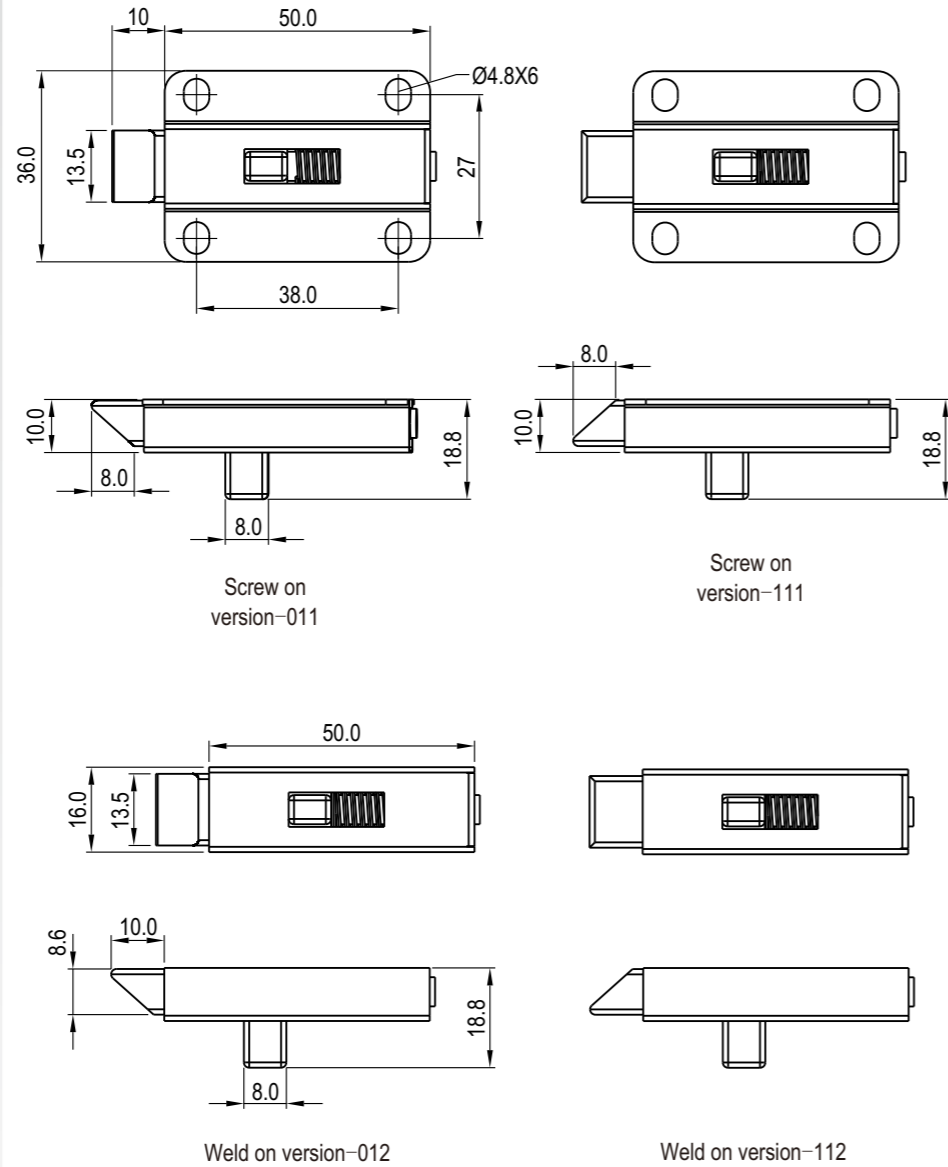
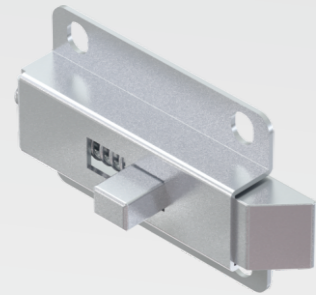

Slam-lock m.s. zinc plated resp. m.s. raw, locking bolt zinc die zinc plated

	Zinc Die	
Screw on version	3600-022-02	3600-222-02
Weld on version	3600-024-02	3600-224-02

Slam-lock

3602

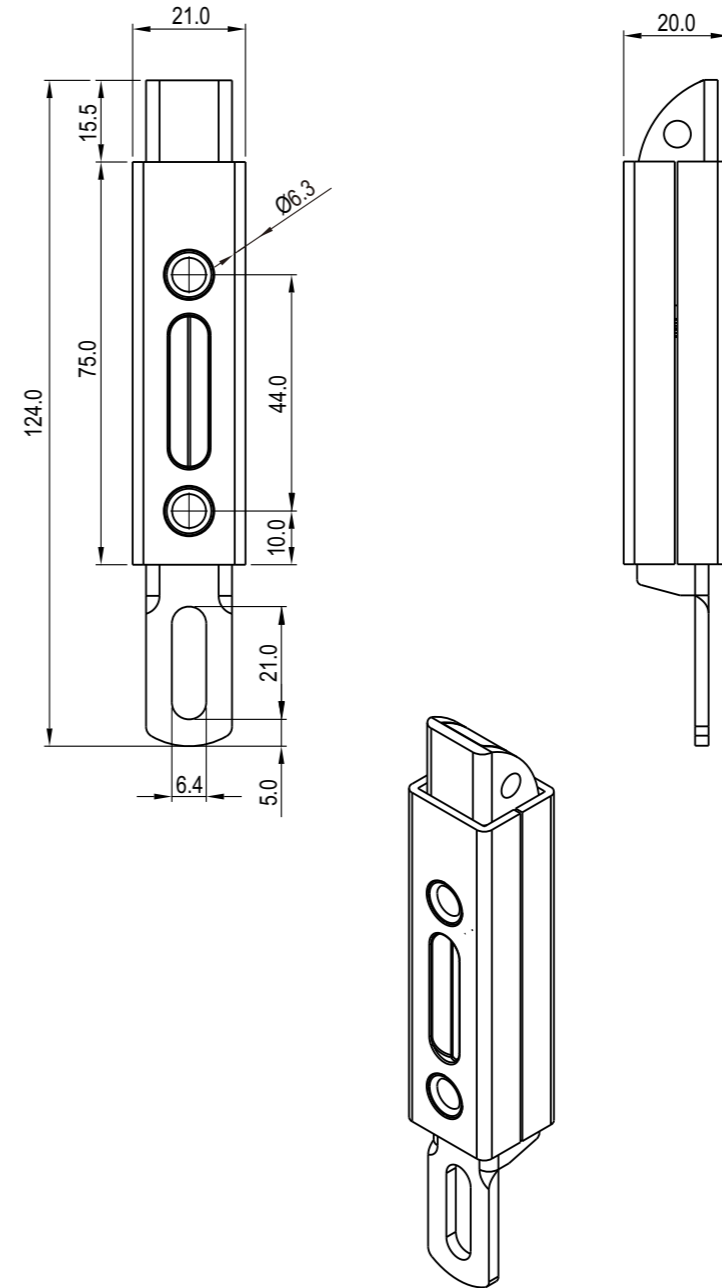

Rod connection can be bent for hand-operation on request



Under development,
shall be available on
December, 2022.

Slam-lock m.s. zinc plated

M.S. zinc plated	3602-022-02
------------------	-------------