

# Screw-on Torque Hinge

4236

# Screw-on Torque Hinge

4238

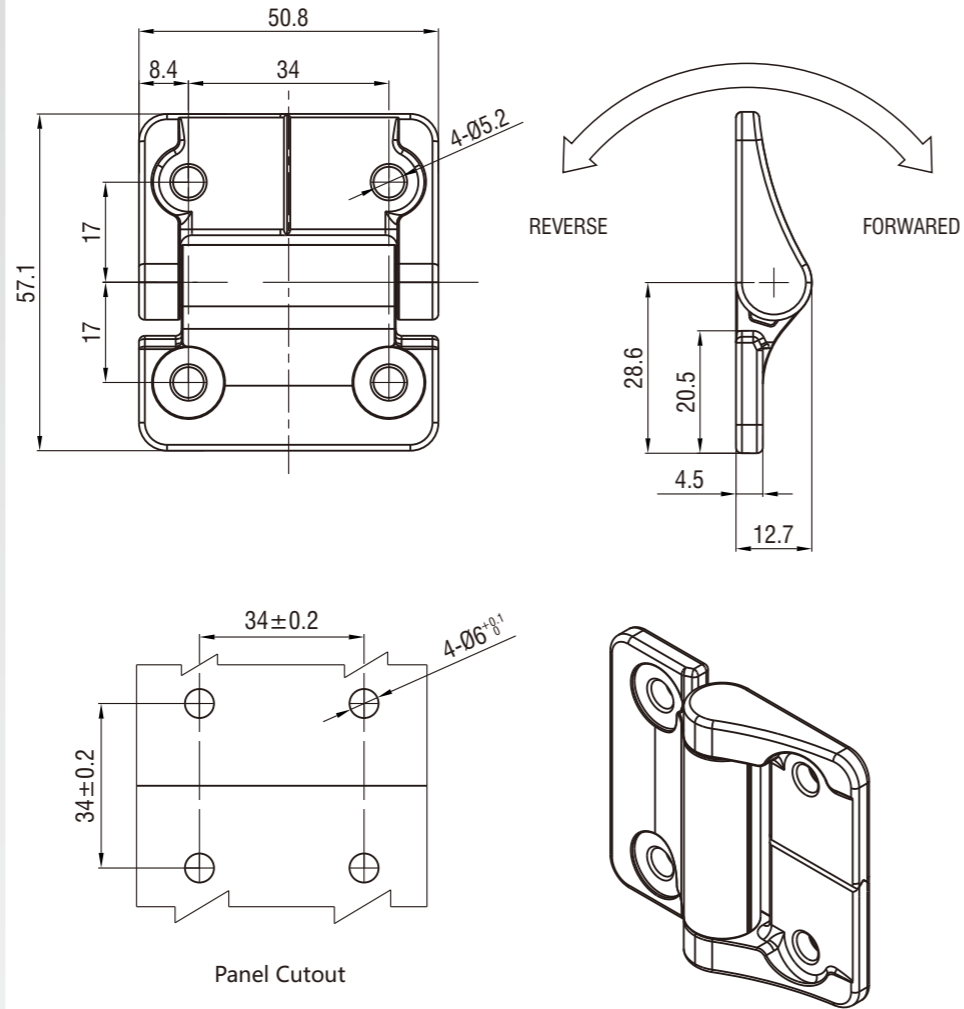
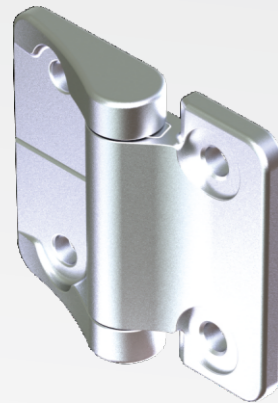

Zinc screw-on torque hinge, SUS pin

N.m Symmetric N.m			
	Black Textured Powder Coated	Natural	
Free Operating	4236-200-40	4236-200-22	
1.8	4236-236-40	4236-236-22	
2.3	4236-246-40	4236-246-22	
3.4	4236-268-40	4236-268-22	

N.m Asymmetric N.m			
Forward Torque N.m	Reverse Torque N.m	Black Textured Powder Coated	Natural
2.3	1.4	4236-246F-40	4236-246F-22
3.4	2.0	4236-268F-40	4236-268F-22
4.5	2.7	4236-290F-40	4236-290F-22
1.4	2.3	4236-228R-40	4236-228R-22
2.0	3.4	4236-240R-40	4236-240R-22
2.7	4.5	4236-254R-40	4236-254R-22

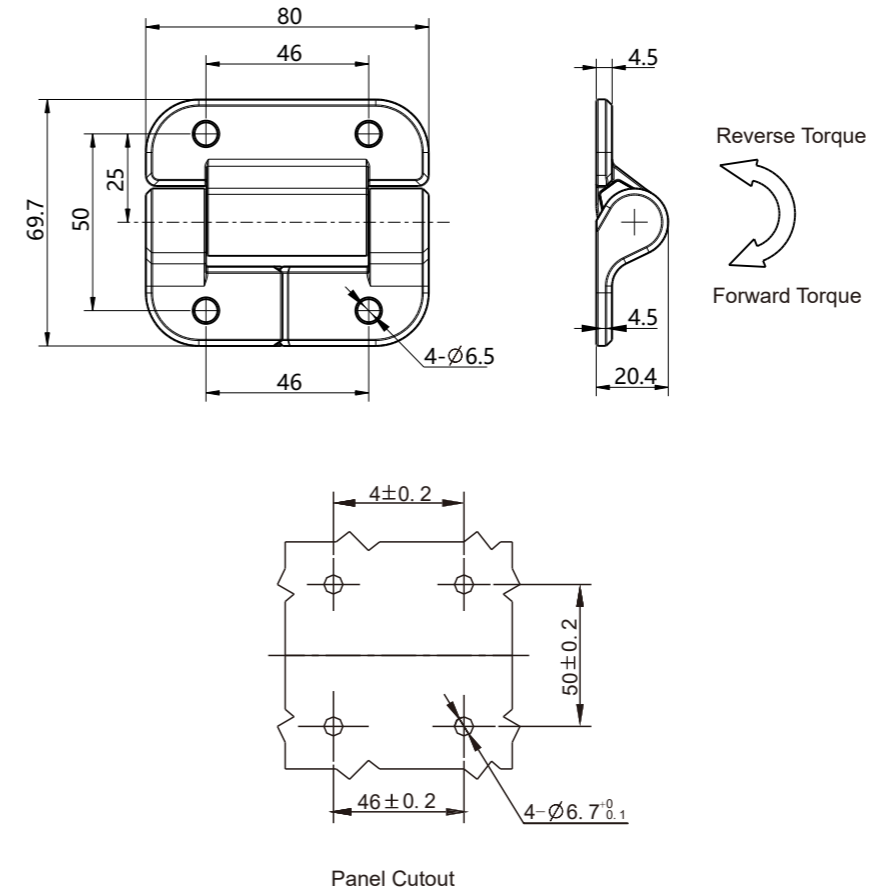

Hinge Zinc Alloy, Black smooth powder coated hinge; Bearing steel pin

N.m Asymmetric N.m			
	Forward Torque	Reverse Torque	
4238-B-4634F-20	2.3	1.7	
4238-B-7860F-20	3.9	3.0	
4238-B-11480F-20	5.7	4.0	
4238-B-14708F-20	7.3	5.4	
4238-B-18134F-20	9.0	6.7	
4238-B-2156F-20	10.7	7.8	
4238-B-2580F-20	12.4	9.0	
4238-B-4634R-20	1.7	2.3	
4238-B-7860R-20	3.0	3.9	
4238-B-11480R-20	4.0	5.7	
4238-B-14708R-20	5.4	7.3	
4238-B-18134R-20	6.7	9.0	
4238-B-2156R-20	7.8	10.7	
4238-B-2580R-20	9.0	12.4	

N.m Symmetric N.m	
Model	Torque
4238-B-46-20	2.3
4238-B-78-20	3.9
4238-B-114-20	5.7
4238-B-146-20	7.3
4238-B-180-20	9.0



**CYCLE LIFE:**  
 Within 20,000 cycles static torque stay  
 Within ±20% of torque specification