

Panel Cutout

Zinc die body, black smooth powder coated

Version A (Cam control)	
Black Smooth Powder Coated	2236-2002-20

Accessories ref. to page #
1. CAM ref. to page 9A-001

Remark
1. Padlockable on request

Swinghandle

2236

Rod Control Swinghandle

2236

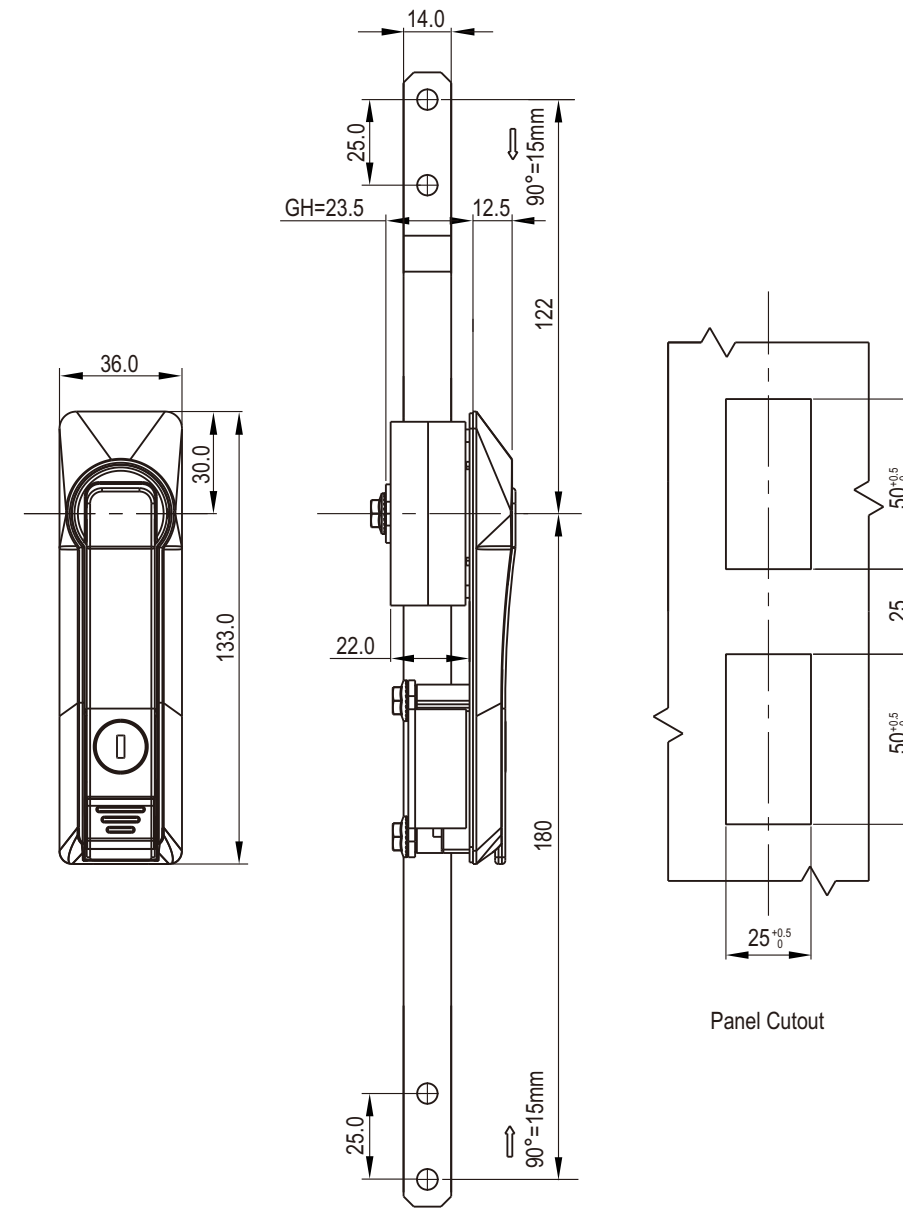

Panel Cutout

Zinc die body and rod control, m.s. zinc plated cam, black smooth powder coated or black E-coated

Version B (2P.rod control)	Version C (3P.rod control)
Black Smooth Powder Coated	Black Smooth Powder Coated
2236-4002-20	2236-6002-20

Remark
1. Padlockable on request
2. Keyed YK333