

RL

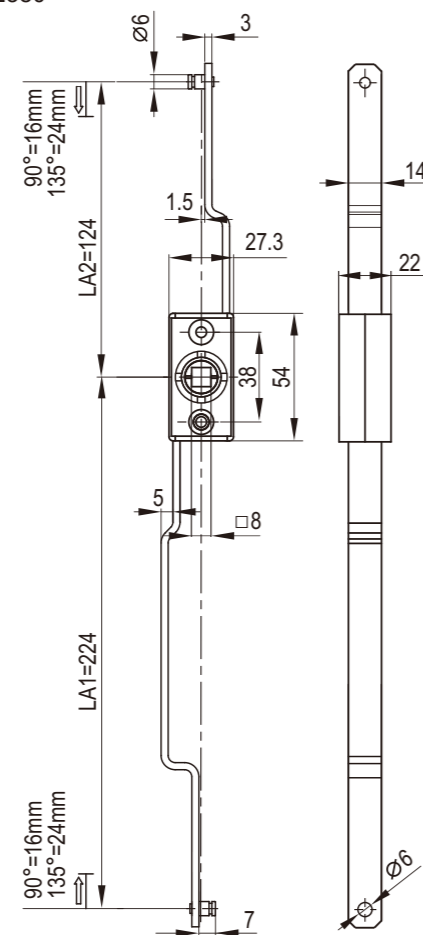

2380



Round Stud

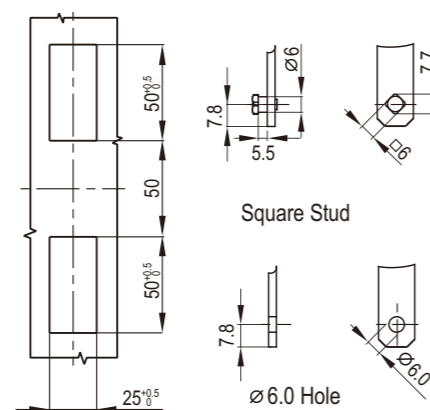

For cutout: Version A

2382

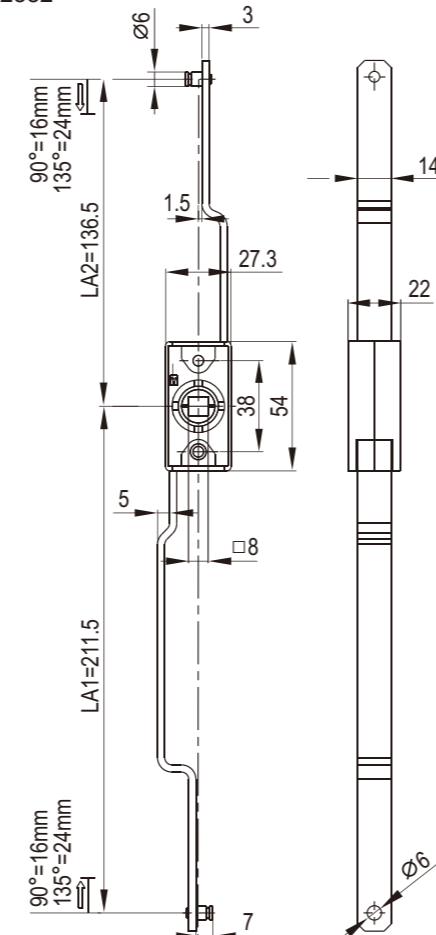

Round Stud

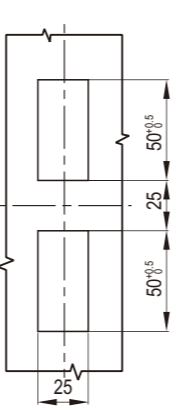

For cutout: Version B

Zinc die body, m.s. zinc plated rod

Rivet Style	For cutout:Version A	For cutout:Version B
Round Studs	2380-02	2382-02
Square Studs	2380-04	2382-04
6.0 Hole	2380-06	2382-06

Rod Control

2384、2388

2384

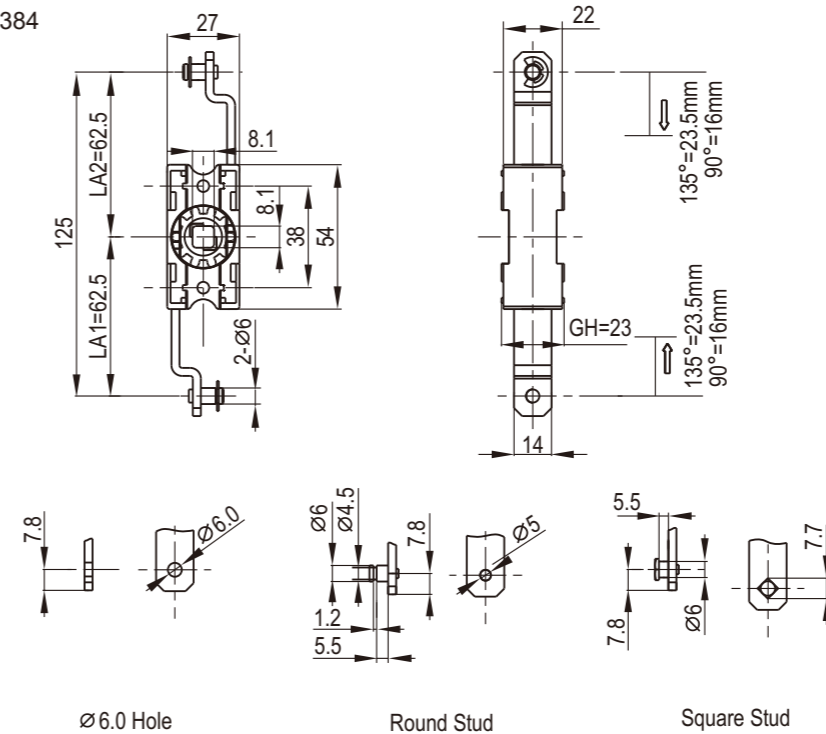

2388

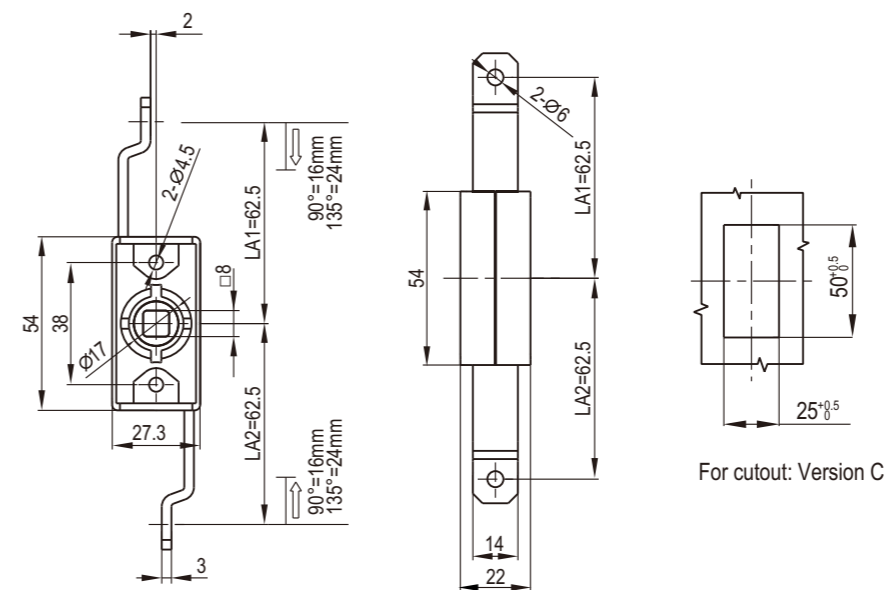

For cutout: Version C

Zinc die body, m.s. zinc plated rod

Rivet Style	For cutout:Version C	For cutout:Version C
Round Studs	2384-02	2388-02
Square Studs	2384-04	2388-04
6.0 Hole	2384-06	2388-06

RL

