

NEW

Slam Latch

2512

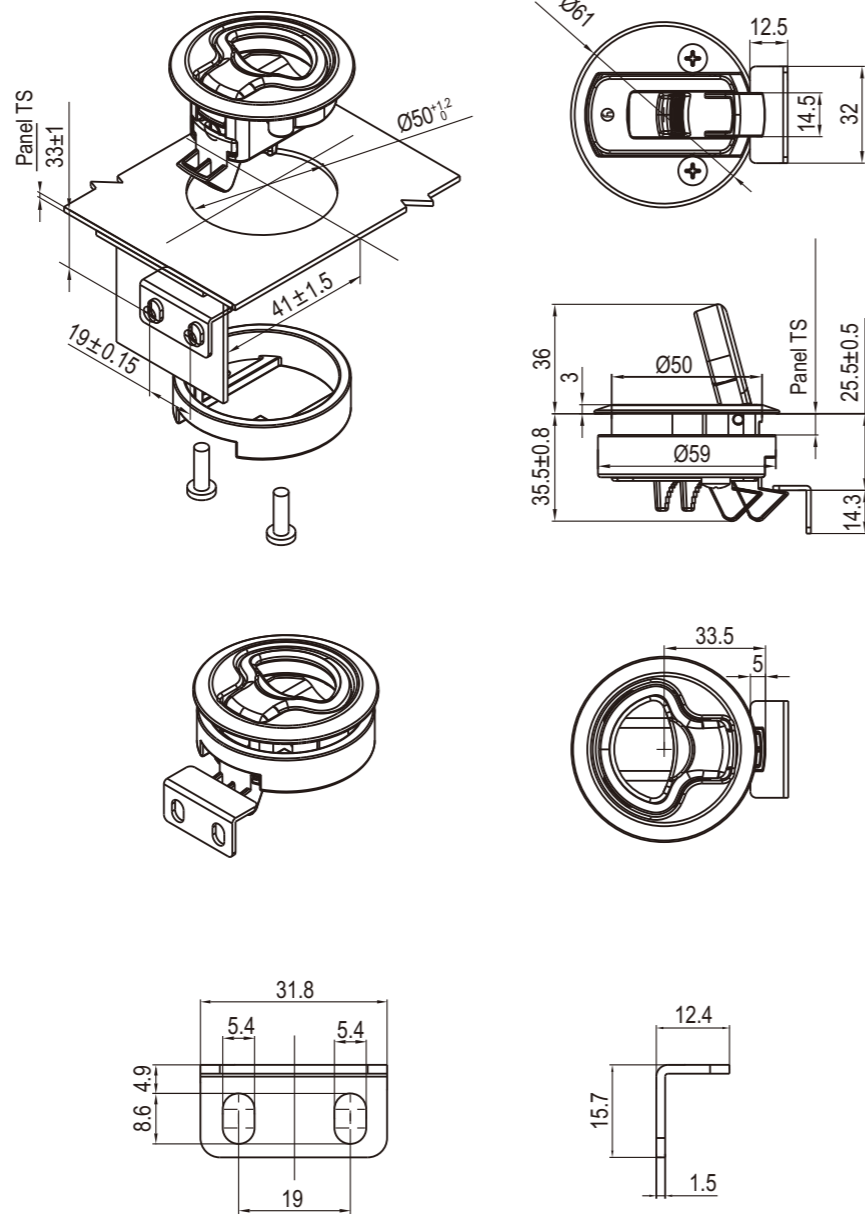
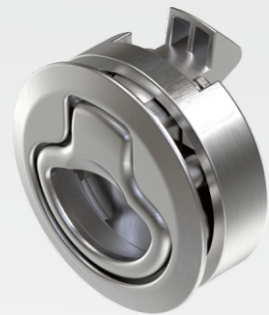

Keyed CH751 key

Plastic, zinc die or stainless steel lock body

Panel thickness		Mounting bracket height	Fixing screw length	Key Locking version (CH751)				Non-locking version			
MIN	MAX			Stainless steel	Acetal black	Acetal Grey	Zinc die	Stainless steel	Acetal black	Acetal Grey	Zinc die
2	7	14	16	2512-20-4-632	2512-20-4-PAB	2512-20-4-PAG	2512-20-4-40	2512-00-4-632	2512-00-4-PAB	2512-00-4-PAG	2512-00-4-40
7	12	14	20	2512-20-14-632	2512-20-14-PAB	2512-20-14-PAG	2512-20-14-40	2512-00-14-632	2512-00-14-PAB	2512-00-14-PAG	2512-00-14-40
12	17	3.8	16	2512-20-24-632	2512-20-24-PAB	2512-20-24-PAG	2512-20-24-40	2512-00-24-632	2512-00-24-PAB	2512-00-24-PAG	2512-00-24-40
17	22	3.8	20	2512-20-34-632	2512-20-34-PAB	2512-20-34-PAG	2512-20-34-40	2512-00-34-632	2512-00-34-PAB	2512-00-34-PAG	2512-00-34-40

Compression Latch

2516

NEW

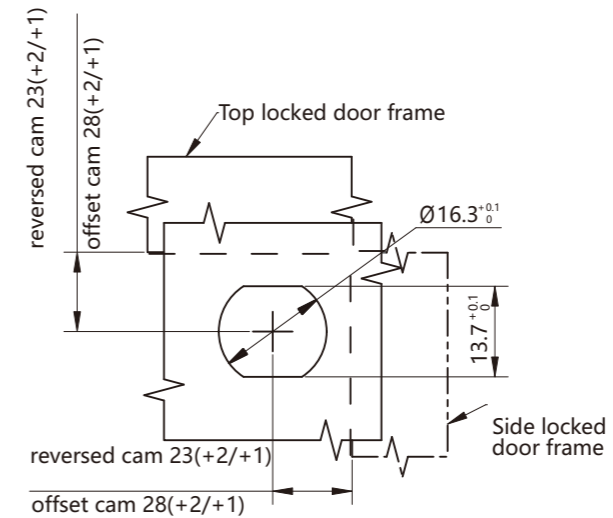
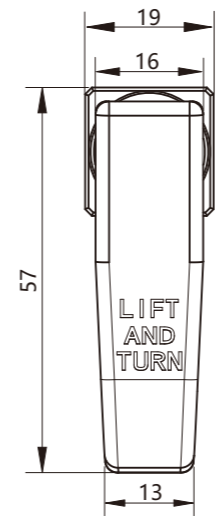
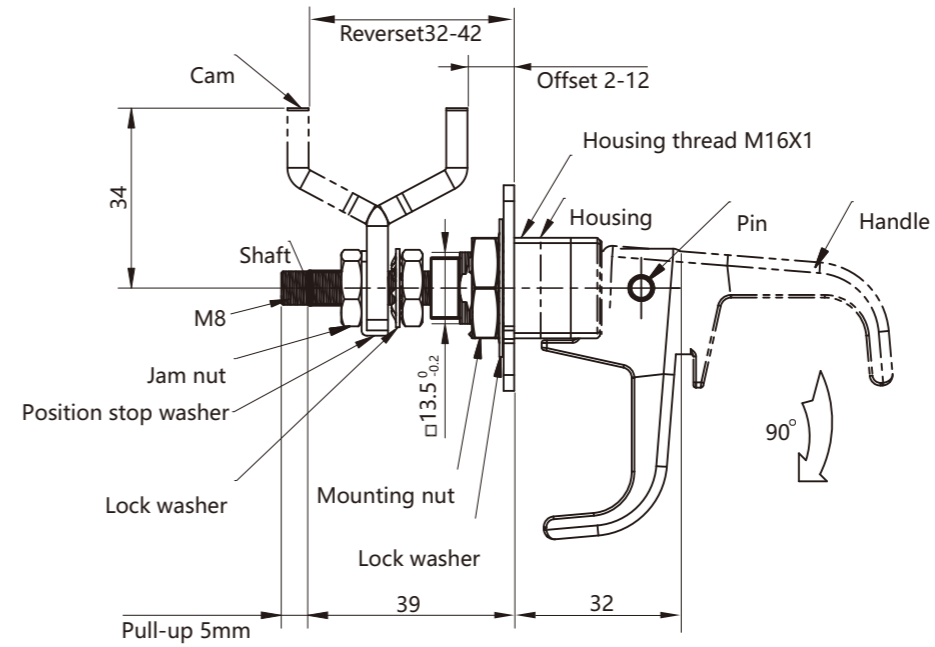

Panel Cutout



Zinc die handle and housing; black smooth powder coated or bright chrome; m.s. zinc plated cam

Grip-Range		Coating	
Pawl Forward	Pawl Reversed	Black Smooth Powder Coated	Bright Chrome
/	42-52	2516-04-220	2516-04-260
2-12	32-42	2516-04-420	2516-04-460
12-22	22-32	2516-04-620	2516-04-660