

Rod Control Swinghandle

2216

Rod Control Swinghandle

2220

Index

Locks

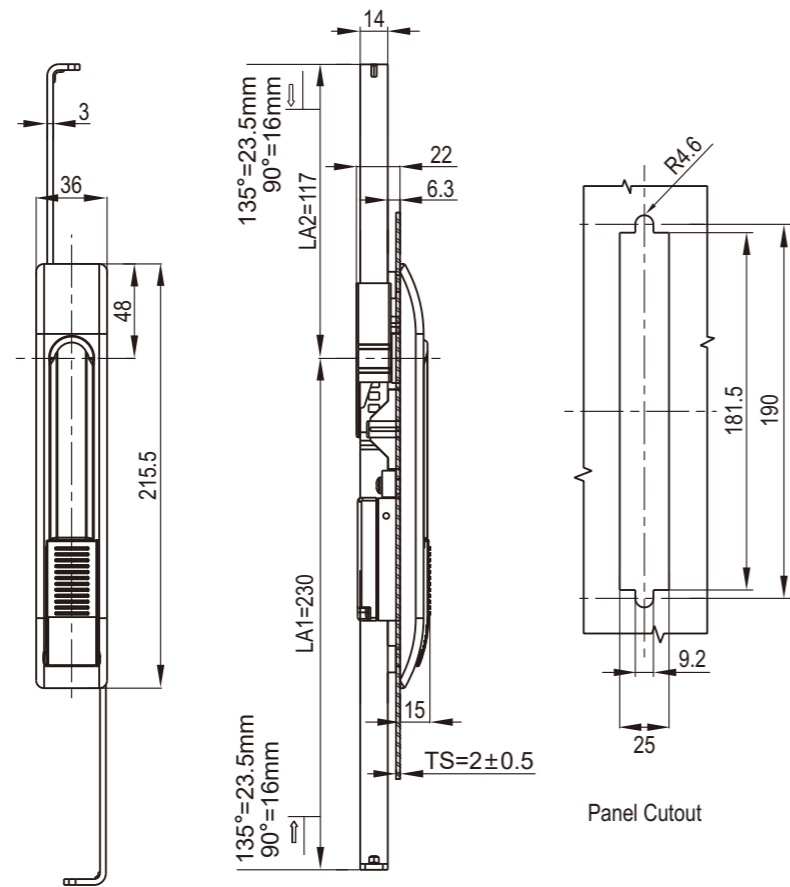
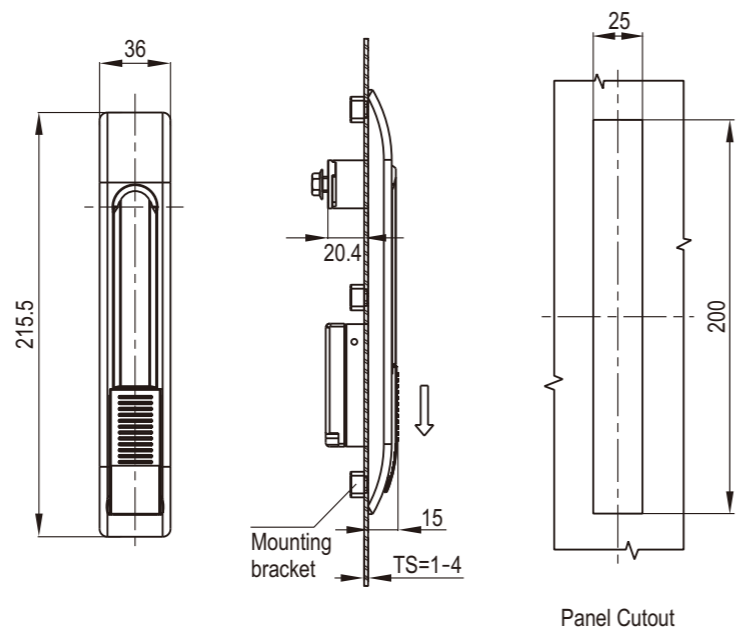
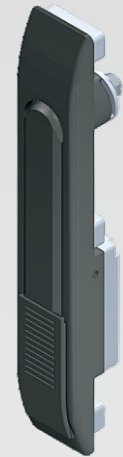
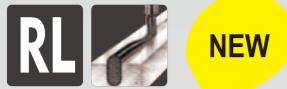

Black PA housing, zinc die handle, black textured powder coated, m.s. zinc plated control flat rod

Version A(Cam control)	Version C(3P.rod control)
Black Textured Powder Coated	Black Textured Powder Coated
2216-2002-40	2216-6002-40

Accessories ref. to page #
1.CAM ref. to page

9A-001Remark

- Key different on request
- CH751 key code on request
- Keyed Yk333

1A-023

Index

Locks

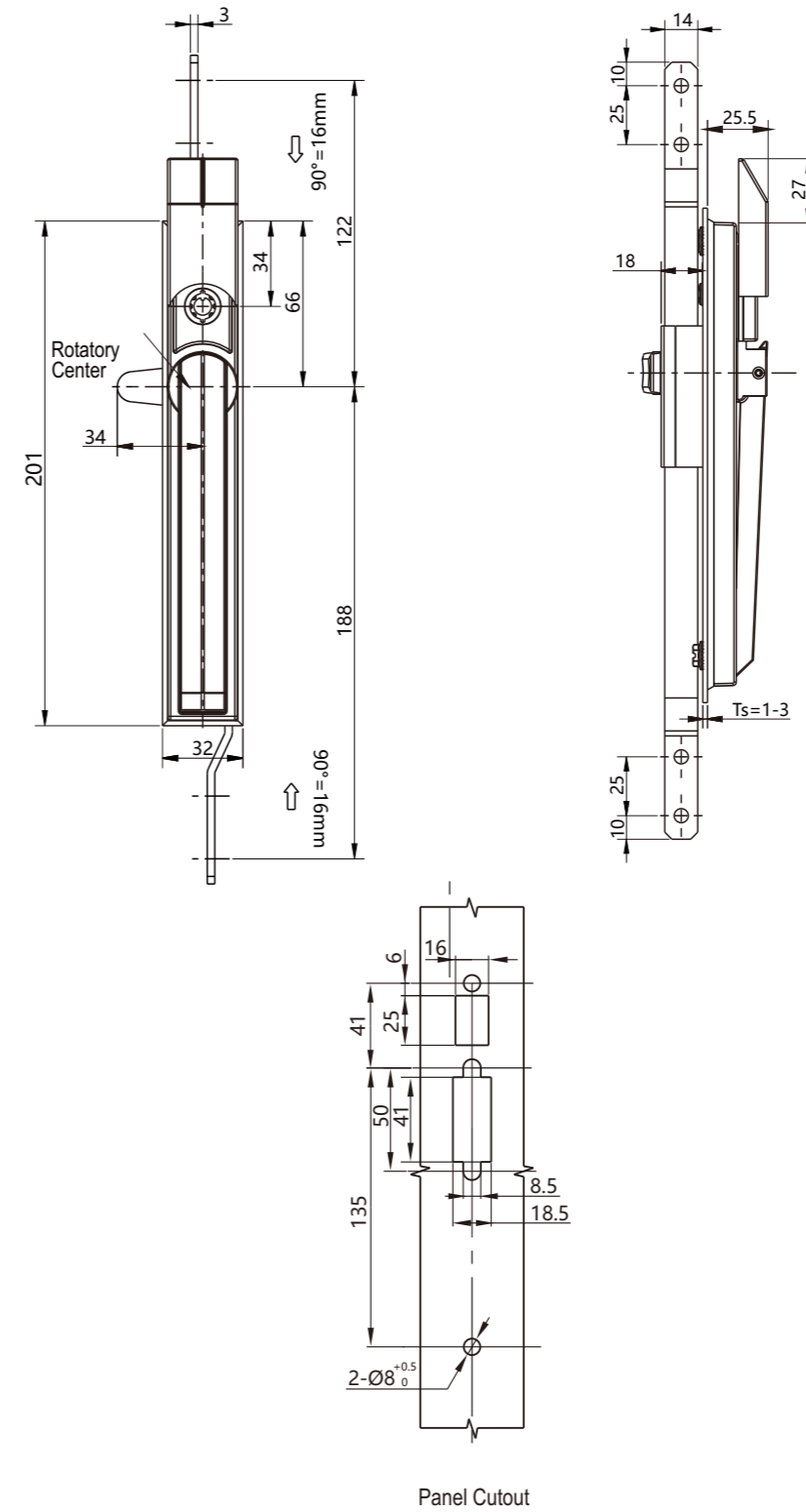
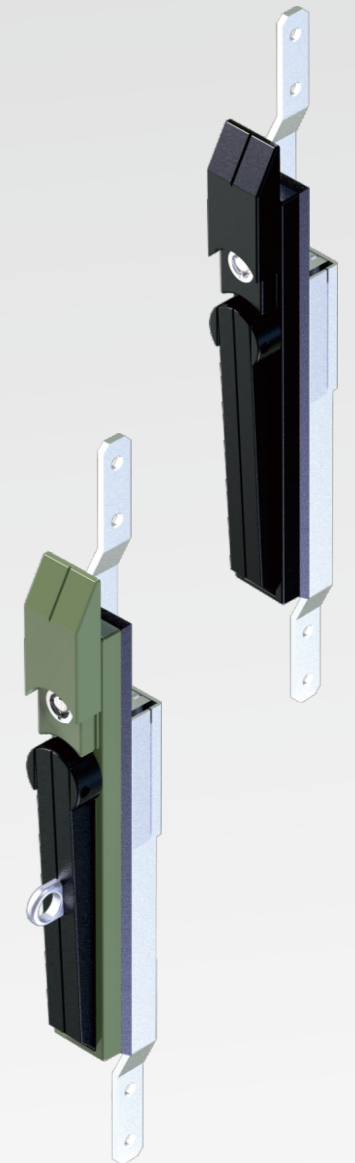

Zinc housing handle, SUS316 padlock device, black smooth powder coated

Version C(3P.rod control)	M.S.plated Cam	Zinc Cam
Black Smooth Powder Coated	2220-6002-20	2220-6002-20-S
RAL7032 Powder Coated RAL7032	2220-6002-64	2220-6002-64-S

Remark

- Padlockable on request

1A-024