

Swinghandle Lock

2402

Swinghandle Lock

2402

Index

Locks

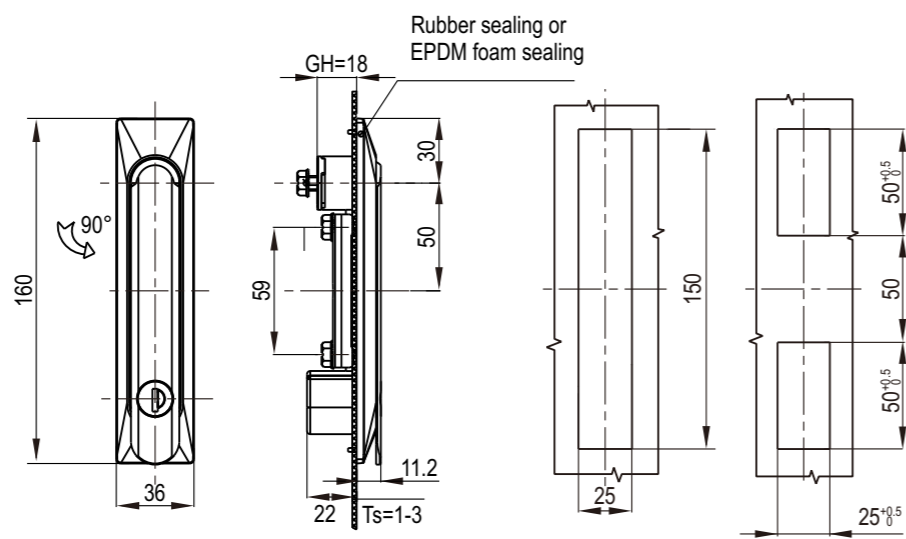

Panel Cutout

PA black plastic or zinc die housing, zinc die handle black powder coated, zinc die shaft and m.s. zinc plated fixing parts

	Zinc die handle, PA housing
Large size GH=18	2402-02-0236

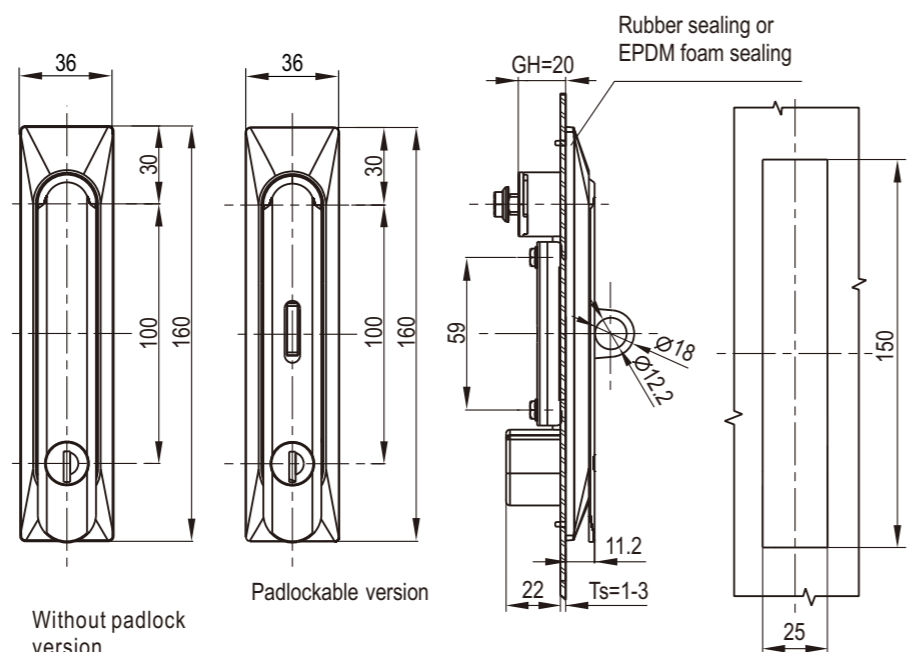

Panel Cutout

PA black plastic or zinc die housing, zinc die handle black powder coated, zinc die shaft and m.s. zinc plated fixing parts

	Zinc die handle, PA housing	Zinc Die
Large size GH=20	2402-02-0240	2402-02-0440

Accessories ref. to page #
1. CAM ref. to page 9A-001

Remark
1. Key different on request
2. CH751 key code on request
3. Padlockable on request
4. Keyed YK333

Index

Locks

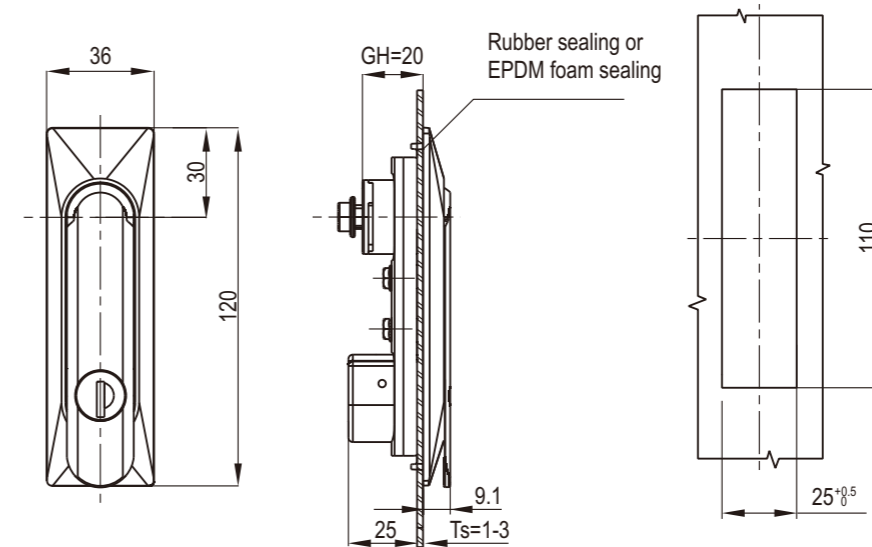

Panel Cutout

Black PA or zinc die lock housing, zinc die handle black powder coated, zinc die shaft and m.s. zinc plated fixing parts

	Zinc die handle, PA housing	Zinc Die	PA
Small size	2402-04-0240	2402-08-0440	2402-08-0640

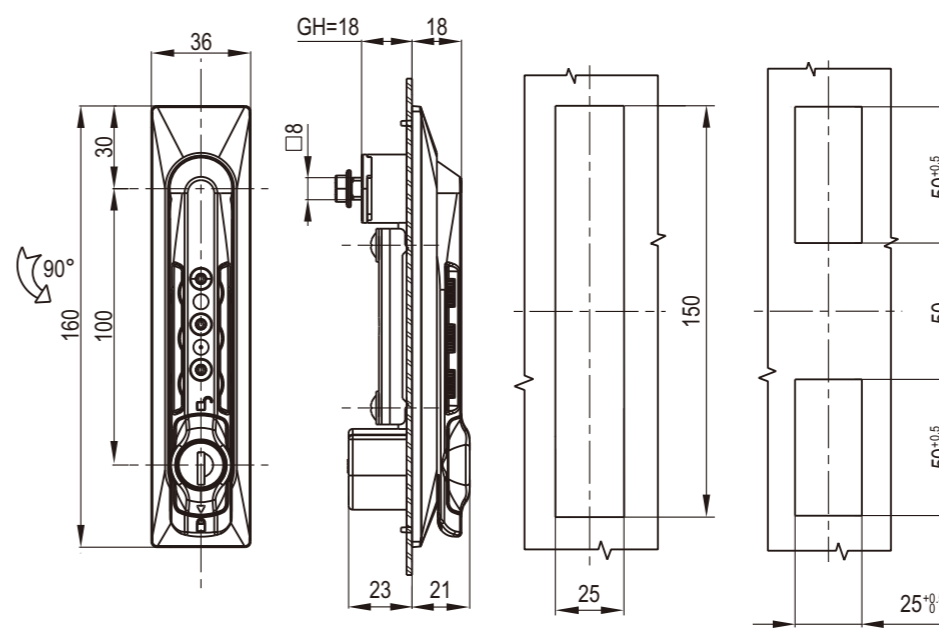

Panel Cutout

PA black plastic or zinc die housing, zinc die handle black powder coated, zinc die shaft and m.s. zinc plated fixing parts

	PA handle and housing
Code mode	2402-02-0640

Accessories ref. to page #
1. CAM ref. to page 9A-001

Remark

1. Key different on request
2. CH751 key code on request
3. Keyed YK333