

Screw-on Torque Hinge

4272

Screw-on Hinge

4274



Countersunk Screw M8

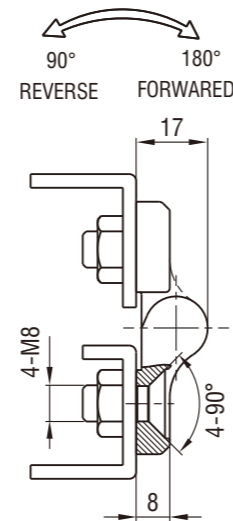
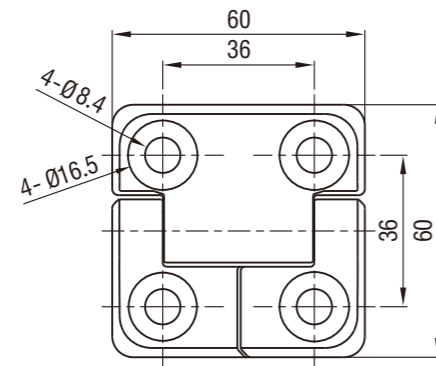

With Threaded Studs M8 60

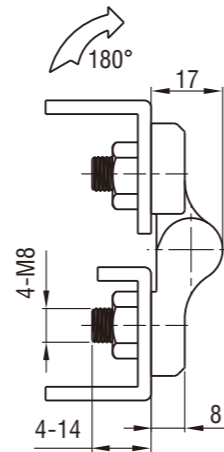
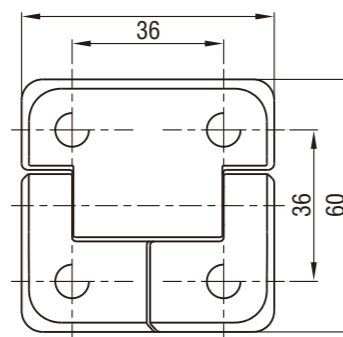

Zinc screw-on torque hinge, SUS pin

N.m Symmetric N.m

	Black Textured Powder Coated	
	Countersunk Screw M8	With Threaded Studs M8
Free Operating	4272-12000-40	4272-12200-40
1.36	4272-12026-40	4272-12226-40
2.26	4272-12044-40	4272-12244-40
3.16	4272-12062-40	4272-12262-40
4.07	4272-12080-40	4272-11280-40

N.m Asymmetric N.m

Forward Torque N.m	Reverse Torque N.m	Black Textured Powder Coated	
		Countersunk Screw M8	With Threaded Studs M8
2.3	1.4	4272-12046F-40	4272-12246F-40
3.2	1.9	4272-12064F-40	4272-12264-40
4.1	2.4	4272-12082F-40	4272-12282F-40
5	3	4272-12010F-40	4272-12300F-40
1.4	2.3	4272-6014R-40	4272-12228R-40
1.9	3.2	4272-12038R-40	4272-12238R-40
2.4	4.1	4272-12048R-40	4272-12248R-40
3	5	4272-12060R-40	4272-12260R-40

CYCLE LIFE:
Within 25,000 cycles static torque stay
Within ±20% of torque specification

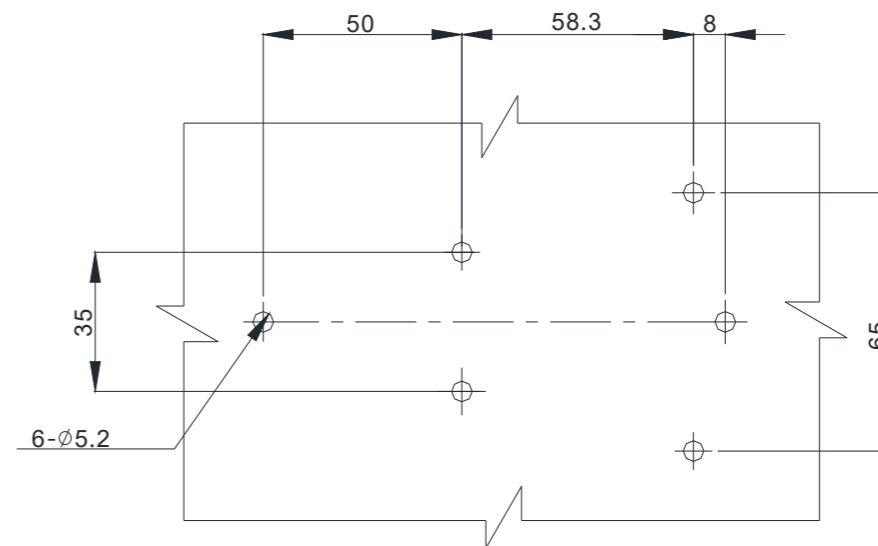
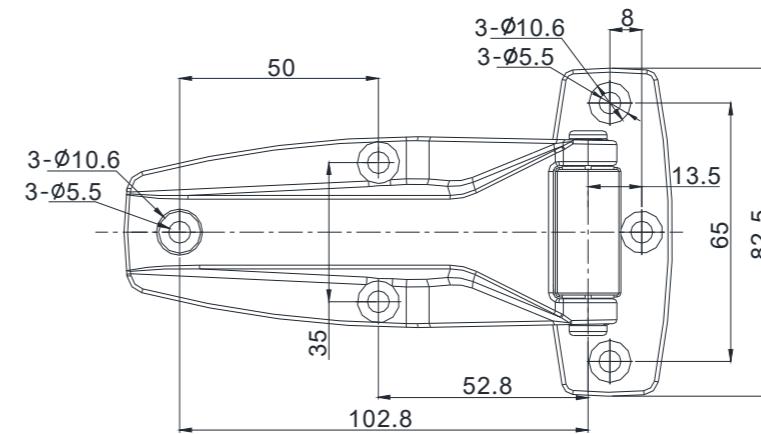
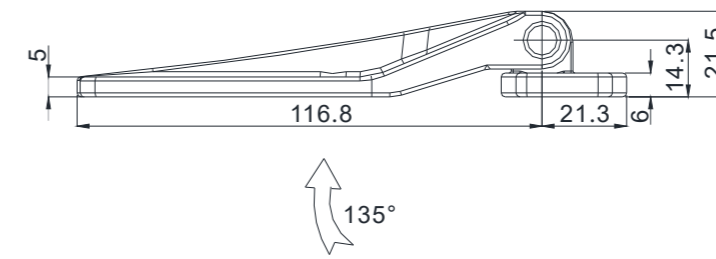

Panel Cutout

Zinc die, black smooth powder coated or bright chrome; Stainless steel, Brushing

Finish	
Black Smooth Powder Coated	4274-1660-20
Bright Chrome	4274-1660-60
SUS304	4274-1660-608

NEW

