

Lever Handle Lock

2244

Rod Control Swinghandle

2248

Index

Locks

RL IP40

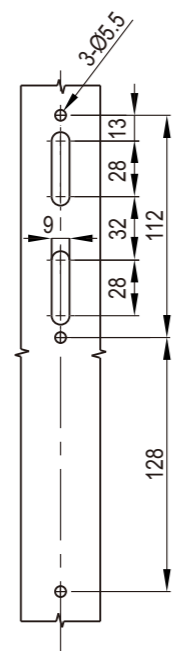
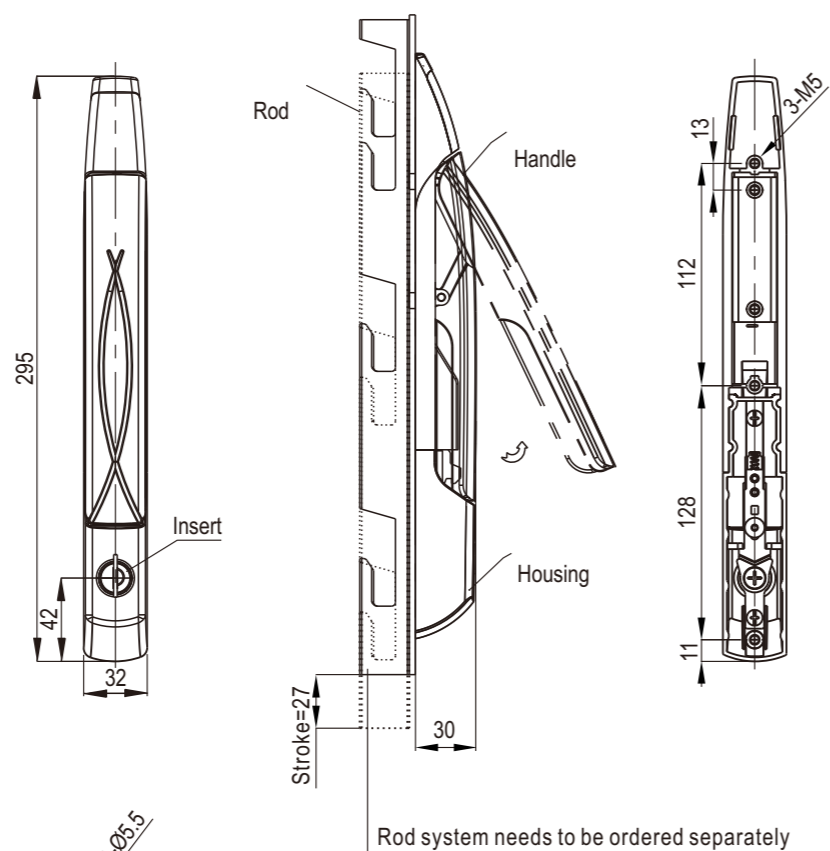

Panel Cutout



Double Bit 4mm

Zinc die, SUS mounting bracket, push plate, baffle plate and pin, black textured powder coated or yellow-grey powder coated (RAL7032)

Cylinder style	Black Textured Powder Coated	Powder Coated RAL7032
1122 Key	2244-4002-40	2244-4002-64
Double Bit 4mm	2244-4028-40	2244-4028-64

Index

Locks

RL IP65

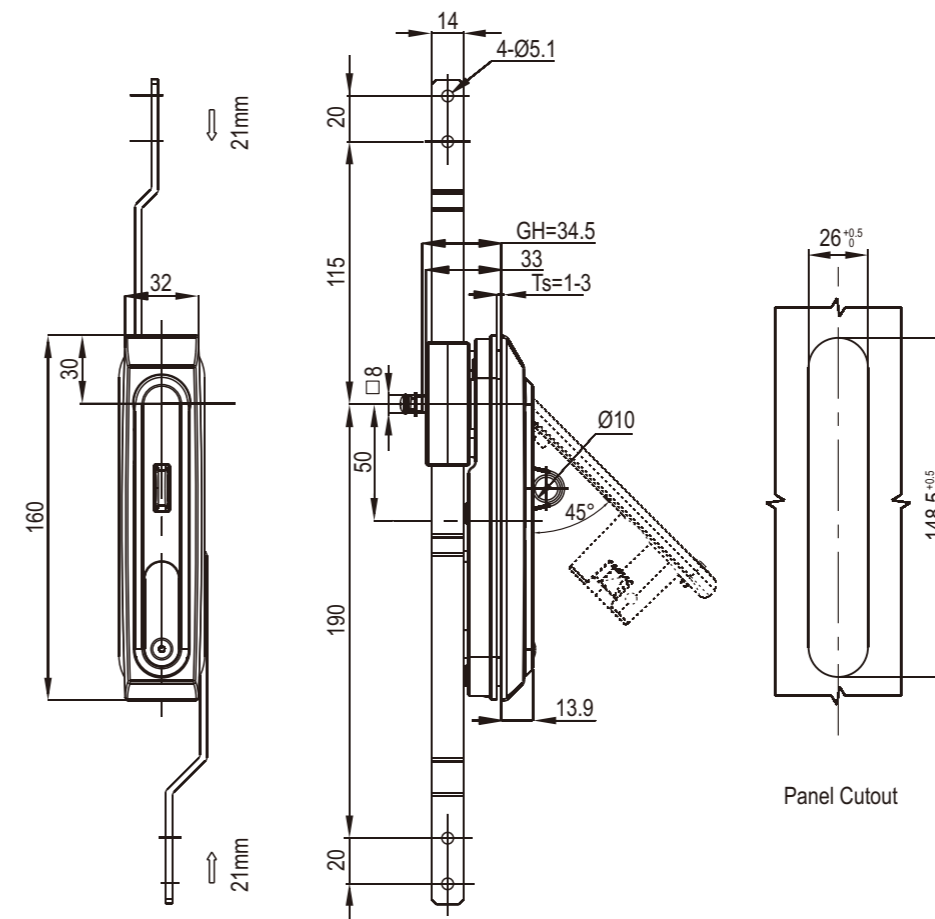

Panel Cutout

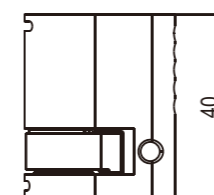

Default profile cylinder

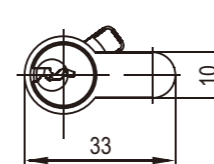

Default key

Zinc die lock body, black finish, stainless steel rod control, padlock device

Version B (2P.rod control)	Version C (3P.rod control)
Without padlock	Padlockable
2248-4P02-110	2248-6P02-110-P

Remark

1. Padlockable on request
2. Interchangeable profile cylinder



Under development, shall be available on December, 2022.